



AUTOMATIC BAR SCREEN

➔ Type XG

SPECIFICITIES

- Downstream waste discharge.
- No limit to screen height.
- Can be adapted to all types of new or existing works (channel, station, etc.).
- Straightforward design = long-term reliability.
- Custom built.
- Low operating costs and easy maintenance.
- Compliant with EC standards.
- Parts subject to wear and electrical equipment are out of water (accessible from installation plane).
- Waste directly recovered in a bin or other receptacle.

TECHNICAL CHARACTERISTICS

Max. rate (m ³ /h)	20,000
Bar spacing (mm)	3 to 60
Width (mm)	450 to 2,000
Maximum depth under installation plane (mm)	17,000
Max. total height (mm)	21,000
Discharge	Downstream
Slope/vertical	0°
Construction	304L, 316L or mixed.
Electrical protection	Current controller



AUTOMATIC BAR SCREEN

➔ Type XG

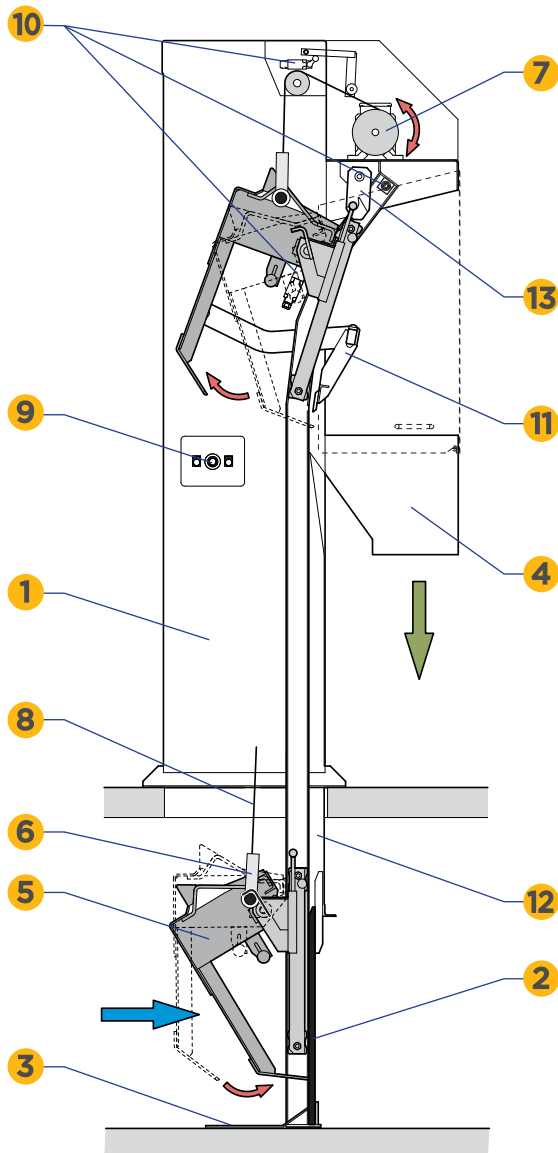

1 • FRAME

Forms casing with attachment parts (by fastening or embedding).

2 • FIXED SCREEN

Welded at lower end. Bar spacing on request.

3 • COLLECTION RECEPTACLE

4 • WASTE DISCHARGE HOPPER

5 • SCOOP/CARRIAGE ASSEMBLY

The carriage slides in the rails. The scoop is equipped with a comb to clean the screen.

6 • MOBILE PART

Attached to the end of the strap, it initiates the opening or closing of the scoop according to its position on one of the two sides of the scoop hinge pins.

7 • GEARED MOTOR

(SEW, P=0.25 to 2.2kW), with single-strap drum. Safetied with hinged casing equipped with a pneumatic actuator.

8 • POLYESTER STRAP

Resistant to all chemical products and freezing (breaking strength = 3.5 or 12 tons according to bar screen dimensions).

9 • MANUAL CONTROL PANEL

Equipped with “up-down” pushbuttons and a emergency stop punch button. The geared motor and limit sensors are connected to it.

10 • POSITION SWITCHES

“Top”, “Very top” and “Bottom”.

11 • EJECTOR

Hinged on a pin and equipped with a scraper made of HD 1000.

12 • WASTE GUIDE

13 • LOCK

OPERATING PRINCIPLE

On receiving the operation signal, the open scoop/carriage assembly slides down to come to rest on the collection receptacle. Under the effect of gravity, the mobile part changes position, the strap slackens and releases a feeler which actuates the “bottom” limit sensor. The motor operating direction is then reversed, the strap is tightened, the scoop closes engaging its teeth in the screen and is raised. At the top, the scoop/carriage assembly releases an ejector which scrapes the comb and pushes the waste to an inclined plane. The “top” end of travel sensor stops the motor and actuates the reverser. The scoop/carriage assembly slides back down and comes to a stop on the lock. The strap slackens and releases the feeler which actuates the “bottom” end of travel sensor. The motor operating direction is reversed again, the strap is tightened, the mobile part changes position and opens the scoop. The “very top” limit sensor stops the motor and actuates the reverser. The open scoop/carriage assembly slides down again for a new cycle.

OPTIONS

Frame made up of several parts according to the depth or location (in building for example), acoustic insulation, manual screen for side by-pass, lateral deflectors, inspection door on hopper, heater to prevent freezing, cleaning ramp, ATEX equipment, metal channel, variable speed geared motor, electrical control and servo-control unit with or without variable speed drive, assembly or help with assembly provided by an FB Procédés technician, etc.